

## Design and manufacture of a low-current ADR magnet for a space application

Brockley-Blatt C., Harrison S.\*, Hepburn I., McMahon R.\*, Milward S.\*, Stafford Allen R.\*

Mullard Space Science Laboratory, Dorking, Surrey RH5 6NT, UK

\*Space Cryomagnetics Ltd, E1 Culham Science Centre, Abingdon OX14 3DB, UK

Adiabatic demagnetisation refrigerator (ADR) systems offer a convenient method for achieving temperatures below 50 mK. The magnet system described in this paper is a key component of the ADR engineering and qualification model for the proposed European Space Agency (ESA) XEUS mission, in which the ADR will be used to cool x-ray detectors. The magnet has been designed as a collaborative project between Mullard Space Science Laboratory (University College London) and Space Cryomagnetics Ltd. This paper describes the design, manufacture, and testing of the coils.

### INTRODUCTION

The number of applications - such as x-ray detectors - requiring temperatures less than 1 K is increasing [1]. Currently the most widely-used systems for achieving these low temperatures are dilution refrigerators and ADRs. But dilution refrigerators are generally complicated, while ADRs are often heavy and cannot provide continuous cooling. However, if the cold stage temperature of an ADR is used in a feedback loop to control the rate of magnetic field discharge, relatively long-term operation at low temperatures is possible. Moreover, with careful design of the superconducting magnets in this particular ADR system, a light, strong assembly suitable for a satellite application has been manufactured.

XEUS requires a two-stage ADR (Figure 1), equipped with salt pills of chromium potassium alum (CPA) for the cold stage and dysprosium gallium garnet (DGG) for the intermediate stage. The salt pills are supported in the clear bore of the magnet on Kevlar strings [2]. The paramagnetic refrigerants were selected to provide an ultimate temperature below 50 mK (target 30 mK) for 24 hours with an ADR cycle time of 4 hours [3]. The heat sink is maintained at a temperature of approximately 4.5 K by a space-qualified cryocooler. A thermal budget of 5 mW is allowed for the ADR and magnets.

Ultimately, the ADR will be part of the proposed ESA XEUS x-ray observatory, and will be launched on an Ariane 5 rocket. The observatory will consist of two satellites: one for the mirrors and one for the focal plane assembly. Together they will orbit the Earth to work as an x-ray telescope. A cryogenic spectrometer, with detectors operating between 30 and 100 mK, is the current baseline system for the ESA XEUS study.

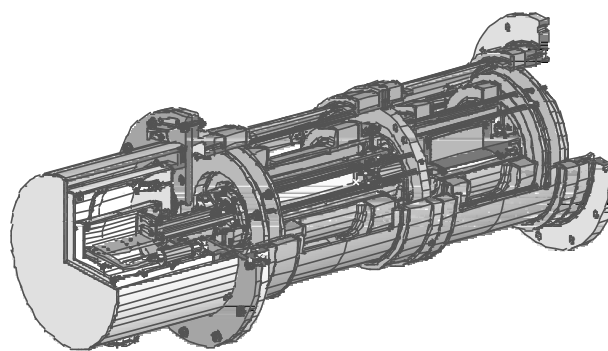

Figure 1 Cut-away view of the ADR assembly

## MAGNET SYSTEM DESIGN

### Magnetic design and shielding

The components of the magnet system were designed and developed with emphasis on the satellite requirements, and on constraints on the overall length and the interactions between the two ADR stages. A number of design iterations were required before the optimum configuration for the solenoids and coils could be identified (Table 1).

Table 1 Parameter list for the superconducting magnet system

Clear bore	65.5 mm
Overall length	400 mm
Outer diameter	215 mm
Maximum field on the salt pill	3.0 T
Maximum operating current	2.5 A
Superconductor	0.1 mm diameter NbTi (235 km total length)
Total magnet system mass	24.08 kg
(of which coil mass)	11.19 kg
Configuration	Solenoids with compensating and active shielding coils
Magnetic shielding	Active with additional passive material
Fringe field	< 67 $\mu$ T 500 mm from the centre
Paramagnetic pill size	0.5 moles (CPA) 1.0 moles (DGG)

The CPA and DGG magnets both consist of a major solenoid with compensating coils at each end, surrounded by the active-shielding coil pairs. All the coils are connected in series, which minimises the number of current leads required. Additional shielding outside the coils is provided by high-permeability material used in the construction of the cryostat. The combination of the shielding materials and Helmholtz biasing coils results in a fringe field of less than 5  $\mu$ T at the detector focal plane, and less than 67  $\mu$ T at a distance of 500 mm from the centre of the ADR.

### Current leads

The leads - which supply current to the magnet coils - operate in vacuum, and therefore have to be thermally anchored to the 4.5 K stage of the cryocooler. However, the cooling power available from the cryocooler is very limited, so it is vital to minimise the heat load from the current leads. For this reason, the magnet has been designed to operate at very low current, using very small (0.1 mm diameter) NbTi superconducting wire, running at 60% of its short sample performance.

### Structural design

The magnet structure consists of a one-piece outer former to maximise rigidity and optimise alignment, with segmented middle and inner formers mounted from it. Sensitivity analyses were performed to determine the effect of relative displacements of each coil in the magnet system, to minimise body forces and define the tolerances required in the alignment of the magnet formers. Stress analyses at three stages of fabrication and operation (winding, cool down and full field operation) were undertaken to assist in the choice of former materials (Figure 2). The CPA and DGG magnets were analysed at field separately, and again with all coils operating simultaneously. Finite Element Analysis was used in conjunction with 3-D CAD to produce the final design of the magnet system. The formers are manufactured from electrically-conductive materials, so ground plane insulation has been incorporated in the construction: insulation components are made from fibreglass and Kapton.

The two solenoids were removed from their mandrels after winding, and inserted in aluminium alloy cylinders for support. The other coils were conventionally wound on formers made from metal matrix composite. The composite material has a number of advantages, including high strength and stiffness for relatively low weight. The thermal contraction of the formers was also tailored to match the contraction of the coils, to minimise thermal stresses.

### Quench protection

For quench protection, the solenoids and coils are subdivided into sections with resistor and diode protection circuits.

### Thermal design

The magnet system consists of two major solenoid coils and eight secondary coils. All are cooled by conduction through heat shunts to the 4.5 K stage cryocooler: there are no liquid cryogenes. Thermal modelling and eddy current analysis have been used to determine the optimum geometry for the heat shunts.

## MAGNET TESTING

The completed magnet system is about to be tested at Space Cryomagnetics Ltd (Figure 4). The test cryostat has a central, room-temperature bore tube through which a Hall probe will be used to plot the field along the axis of the magnet. The DGG magnet has already been tested in isolation, and reached its design field after a single training quench.

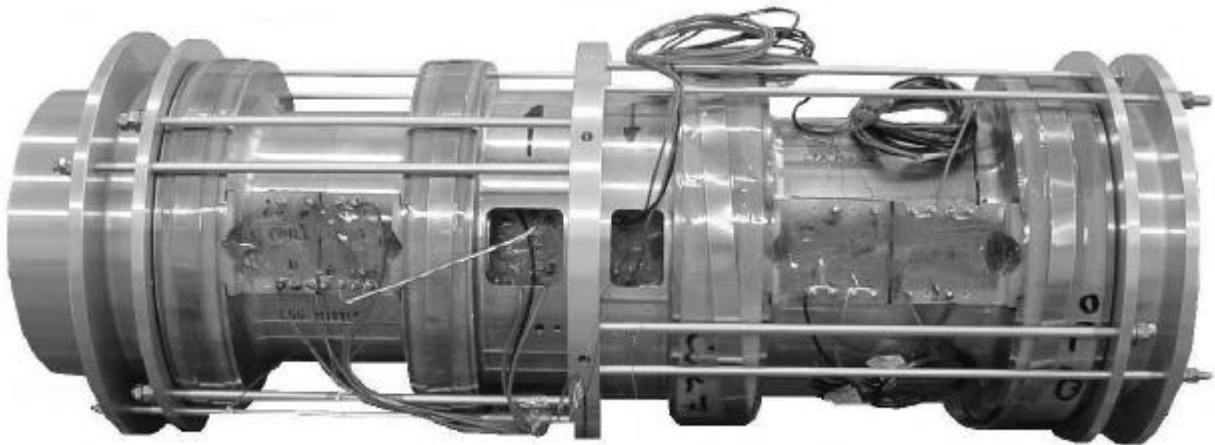

Figure 4 The ADR magnet partly assembled

## SUMMARY

A low-operating current ADR magnet has been constructed as part of the development of the XEUS x ray observatory satellite. The requirements for a cryogen-free, low current, lightweight, actively shielded ADR system are met by this design. Use of metal matrix composites in the formers, and the unusually small size of the superconducting wire, are novel aspects of the construction of this system.

## REFERENCES

1. Proceedings of the Ninth International Workshop on low temperature detectors, AIP conference proceedings, **605**, 2001
2. Hepburn, I.D., et al "Space Engineering Model Cryogen Free ADR For Future ESA Space Missions" Proceeding of CEC 2003
3. Bromiley, P.A., Hepburn, I.D. and Smith, A. "Ultra Low Temperature Cryogen Free Refrigerators" in 6th European Symposium on Space Environmental Control Systems, ESA SP-400 Netherlands 1997 pp507-513