

Cryogenic Temperature Monitors

Model 12 and Model 14

Two or four input channels with Ethernet connectivity

Cryo-con's Model 12 and 14 are the most flexible and accurate temperature monitors currently available. These two or four channel monitors have a level of sophistication not found in other products. Virtually any cryogenic temperature sensor from any manufacturer can be selected by a single setting of the front panel. Additional custom or specially calibrated sensors require only a simple setup procedure. In addition to its high accuracy/performance and low noise design, unique features include: Constant-Voltage AC sensor excitation, Internal Data Logging, Ethernet Connectivity, a large easy to read display and extensive utility software

Ethernet connectivity adds a new dimension of utility to these monitors. In both industrial and laboratory applications, Ethernet is more reliable and easier to use compared to other communication standards. Furthermore, it is essential to remote, distributed sensor or Local Area Network based systems.



- Two models available. The Model 14 has four input channels and the Model 12 has two. All channels are identical in function.
- Multipurpose input channels support Diode, Platinum RTD and cryogenic NTC resistive temperature sensors.
- Constant-Voltage, AC excitation of resistive sensors increases temperature range and improves sensitivity.
- Analog voltage output plus two programmable dry-contact relays.
- Continuous data logging into internal Non-Volatile memory.
- High speed Ethernet interface. Electrically isolated.
- Built-in web server. Temperature monitoring and instrument configuration can be performed using any web browser.
- TCP/IP User Data Socket for complete remote operation using a simple IEEE-488 like command language.
- SMTP interface sends e-mail on a selected alarm condition.
- LabView drivers available for both the Ethernet (TCP/IP) and serial port.



Flexibility: The Model 14 has four independent and identical multi-purpose sensor inputs whereas the Model 12 has two. Each can be easily configured to support virtually any cryogenic temperature sensor. Configuration is performed from the instrument's front panel or a remote interface. There are no jumpers, trim pots or switches.

Silicon Diode sensors from Cryo-con or any other manufacturer are directly supported over their full 1.4 to 500K range using built-in calibration curves and sensor data. Plus, non-volatile Flash memory is available for several custom or calibrated sensors.

Platinum RTD sensors can use built-in DIN 43760 (IEC 750) standard setups for 100Ω or 1,000Ω devices. The Model 12/14 uses the DIN standard for temperatures from 70K to 1020K and extends it down to 30K for cryogenic use. Operation down to about 14K is available using user supplied curves.

A unique feature of these monitors is the use of a ratiometric resistance bridge technique to measure Platinum RTD sensors. This significantly reduces low frequency noise and drift to provide rock-solid measurements.

These monitors provide robust support for the Negative Temperature Coefficient (NTC) sensors commonly used by cryogenic applications. They include **Ruthenium-oxide**, **Cernox™**, **Carbon-Glass™**, **Germanium** and several others. Since they have a negative temperature coefficient, the constant-voltage measurement method will reduce, rather than increase, power dissipation in the sensor as temperature decreases. By maintaining the lowest possible power level, sensor self-heating is minimized and useful temperature range is greatly increased.

An additional advantage to constant-voltage biasing is that NTC resistors lose sensitivity in the upper part of their range. By auto-ranging excitation current to maintain a constant voltage, sensitivity and noise immunity in that range is greatly improved.

Sensor excitation used in conjunction with the constant-voltage feature is a 2.5Hz bipolar square wave. This effectively cancels thermal EMF induced offset errors that sometimes occur in cryogenic systems. The maximum and minimum sensor resistance that can be read is a function of the selected voltage bias.

Resistance Range Table		
Voltage Bias	Min. Resistance	Max. Resistance
10.0mV	10Ω	1.0MΩ
3.33mV	3.3Ω	430KΩ
1.0mV	1Ω	100KΩ

Accuracy: Measurement accuracy is obtained by using a 24-bit analog to digital conversion. Accuracy is further enhanced by extensive use of Digital Signal Processing (DSP) techniques.

The Model 12/14 include built-in curves that support most industry standard temperature sensors. Additionally, four **user calibration curves** are available for custom or calibrated sensors. Each curve may have up to 200 entries.

The accuracy of any sensor can be greatly improved by the use of Cryo-con's **CalGen®** feature. This will fit a Diode, Platinum RTD or NTC resistor sensor's calibration curve at up to three user specified temperature points. It is a built-in, easy to use method for obtaining higher accuracy temperature measurements without expensive sensor calibrations.

Lowest Noise: These monitors were designed for use in extremely low noise environments that cryogenic systems often require. Linear-mode power supplies are used throughout and sensor excitation current sources are not multiplexed.

The enclosure is all Aluminum with wide conductive overlaps on all mating metal surfaces so that radiated RFI noise is virtually eliminated. An effective shielding and grounding scheme further allows the user to minimize both conducted and radiated noise.

Easy to use: The Model 12/14 front panels consists of a large, bright Vacuum Fluorescent display and a 5-key keypad. Most features and functions can be accessed via this simple and intuitive menu driven interface.

Two temperature readings can be displayed in a large, easy to read 10mm two-line font. Underlying menus switch to a 5mm high four-line font for more content. Additionally, the Model 14 can display all four inputs plus alarm and relay status in this smaller font.

Temperature displays are autoranged to show the most number of significant digits. Built-in digital filters can be used to smooth temperature data. Displays are in units of K, °C, °F, Volts or Ohms.

The status of built-in alarms and relays are indicated by LEDs located to the right of the display.

Complex operations such as installing a new sensor require a remote interface connection.

Outputs: The Model 12/14 each have two dry-contact **relay outputs**. Either may be independently programmed to assert or clear based on a high or low temperature condition. Normally-open contacts are available on the rear panel.

Also available is a single **analog output** channel. This is a zero to 4 Volt output that is proportional to any selected input.

Data logging is performed by continuously recording temperature and status to an internal 20K byte circular memory buffer. Data is time stamped so that the actual time of an event can be determined. Non-volatile memory is used so that data will survive a power failure.

Ethernet: The Model 12/14 connects directly to any **10-BaseT Ethernet** interface to make measurements easily and economically -- just about anywhere. Simple connection to any existing Local Area Network allows stable, precise, cost-effective measurements in laboratory or industrial environments as well as in remote, distributed data acquisition systems. The Model 12/14 can even be connected directly to the Internet with a user-supplied IP address.

Using the Ethernet **HTTP** protocol, the monitor's

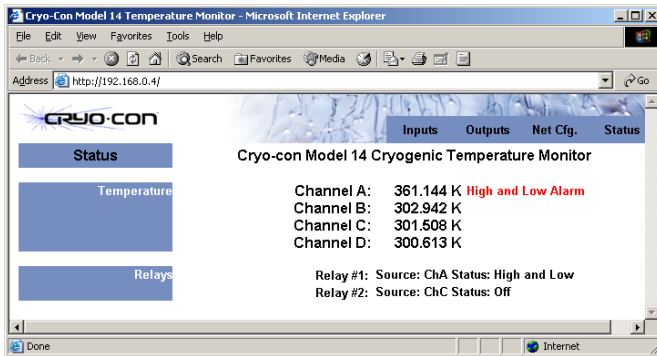

embedded web server allows the instrument to be viewed and configured from any web browser. An example 'Status' page is shown here.

Input channels can be configured using text entry and drop-down box selections by going to the monitor's 'Inputs' web page.

Using the **SMTP** protocol, the monitor will send e-mail based on selected alarm conditions. E-mail is completely configured by using the web page interface.

The **TCP/IP data port server** brings fast Ethernet connectivity to all common data acquisition software programs including LabView™.

TCP/IP protocol is used to implement a text based command language like those commonly used with IEEE-488 or RS-232 interfaces. This is the primary way that user software interfaces to the monitor.

The remote command language is SCPI compliant according to the IEEE specification.

With Ethernet connectivity, the user has complete control of the monitor by using any web-enabled device from desktop PC to a wireless Pocket PC™. It is platform and operating system independent, working equally well with Windows, Linux or Macintosh based computers. There are no expensive cards or cables and, best of all, no confusing configuration requirements.

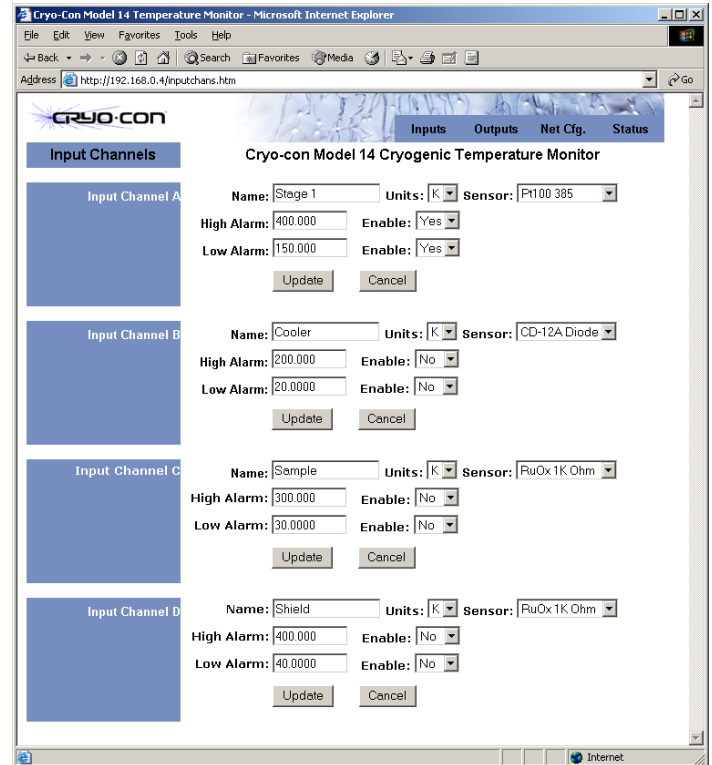

Software: Utility software is provided that connects any Windows based personal computer to either monitor. This software provides a graphical control panel that greatly simplifies instrument setup and configuration.

Sensor calibration curves may be downloaded to the monitor, viewed and edited. Most file formats are directly supported and can be easily converted to Cryo-con's® standard format.

LabView: LabView™ drivers are provided for both the Ethernet TCP/IP and RS-232 interfaces.

Rear panel connections

- Input Connectors: Two DB-9 recepticals provide 4-wire measurement connection to two sensors each.
- LAN: Standard RJ-45 Ethernet connector with built-in connection and activity LEDs.
- RS-232: Null-modem connector (DB-9, pins).
- Relays / Analog Output: 6-pin detachable terminal block. 3.5mm.
- AC Power: RFI filtered Power Entry Module including AC power line switch and fuse drawer. Line voltage selection is performed by internal jumpers.

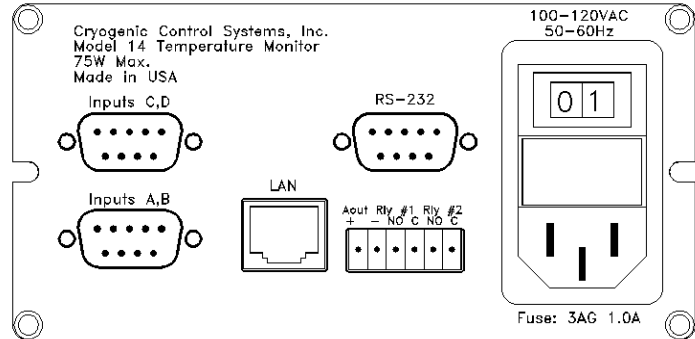

Ordering Information

Part Number	Description
Model 12-110	Two-channel monitor set for 90 to 120VAC..
Model 12-220	Two-channel monitor set for 200 to 240VAC.
Model 14-110	Four-channel monitor set for 90 to 120VAC..
Model 14-220	Four-channel monitor set for 200 to 240VAC.

Sensor Performance Data						
Sensor Type	Silicon Diode	100Ω Platinum DIN43760	1000Ω Platinum DIN43760	Ruthenium Oxide ¹	Carbon-Glass™ ¹	Cernox™ ¹
Sensor Sensitivity	300K: 2.4mV/K 77K: 1.9mV/K 4.2K: 30mV/K	800K: 0.36Ω/K 300K: 0.39Ω/K 77K: 0.42Ω/K 30K: 0.19Ω/K	600K: 3.7Ω/K 300K: 3.9Ω/K 77K: 4.2Ω/K 30K: 1.9Ω/K	1.0K: 1260Ω/K 4.2K: 80.3Ω/K 20K: 3.96Ω/K	1.4K: 520KΩ/K 4.2K: 422Ω/K 77K: 0.1Ω/K 300K: 0.01Ω/K	1.4K: 240KΩ/K 4.2K: 2290Ω/K 77K: 2.15Ω/K 300K: 0.16Ω/K
Measurement Accuracy	300K: 21μV 77K: 23μV 4.2K: 44μV	800K: 2.4mΩ 300K: 2.4mΩ 77K: 1.2mΩ 30K: 1.2mΩ	600K: 38mΩ 300K: 38mΩ 77K: 4.7mΩ 30K: 4.7mΩ	1.0K: 1.9Ω 4.2K: 1.4Ω 20K: 1.09Ω	1.4K: 728Ω 4.2K: 0.58Ω 77K: 14mΩ 300K: 0.02Ω	1.4K: 675Ω 4.2K: 5.1Ω 77K: 161mΩ 300K: 40mΩ
Temperature Measurement Accuracy	300K: 8.7mK 77K: 12mK 4.2K: 1.6mK	800K: 6.7mK 300K: 6.2mK 77K: 2.8mK 30K: 9.8mK	600K: 6.2mK 300K: 6.2mK 77K: 2.8mK 30K: 9.8mK	1.0K: 1.9mK 4.2K: 17mK 20K: 275mK	1.4K: 1.4mK 4.2K: 1.4mK 77K: 150mK 300K: 2.1K	1.4K: 2.2mK 4.2K: 2.2mK 77K: 75mK 300K: 295mK
Measurement Resolution	300K: 7.4μV 77K: 7.4μV 4.2K: 15μV	800K: 1.8mΩ 300K: 1.8mΩ 77K: 460μΩ 30K: 460μΩ	600K: 15mΩ 300K: 15mΩ 77K: 1.8mΩ 30K: 1.8mΩ	2.0K: 11mΩ 4.2K: 11mΩ 20K: 11mΩ	4.2K: 11mΩ 77K: 0.2mΩ 300K: 0.2mΩ	4.2K: 46mΩ 77K: 1.8mΩ 300K: 0.5mΩ
Temperature Resolution	300K: 3.0mK 77K: 3.8mK 4.2K: 500μK	800K: 5.1mK 300K: 4.7mK 77K: 1.1mK 30K: 2.4mK	600K: 4mK 300K: 4mK 77K: 0.5mK 30K: 1.0mK	2.0K: 32μK 4.2K: 0.13mK 20K: 2.9mK	4.2K: 30μK 77K: 1.2mK 300K: 12mK	4.2K: 50μK 77K: 0.85mK 300K: 3.5mK
Power Dissipation	4.2K: 17μW 77K: 12μW	30K: 3.7μW 77K: 20μW	30K: 370nW 77K: 2.0μW	1.0K: 42nW 4.2K: 73nW	1.4K: 962pW 4.2K: 171nW	1.4K: 1.1nW 4.2K: 20nW
Magneto-resistance	Very Large	Moderate	Moderate	<2% for H<2T	Moderate	<1% for H<2T

¹ 10mV Constant-Voltage excitation.

Silicon Diode sensors use a fixed excitation current of 10μA and an input voltage range of 0 to 2.5V.

Both Negative and Positive Temperature Coefficient (NTC) / (PTC) resistor sensors are supported using a ratiometric bridge technique to cancel low frequency noise.

PTC sensor types include: **Platinum** and **Rhodium-Iron**. Excitation currents are 1.0mA, 100μA and 10μA DC. Corresponding full-scale resistance ranges are: 312Ω, 3.2KΩ and 31KΩ.

NTC sensors include: **Ruthenium Oxide**, **Carbon-Glass™**, **Germanium** and **Cernox™**. Constant-voltage AC sensor excitation allows the use of these sensors over an extended temperature range. Excitation voltage selections are 10mV and 1.0mV.

GaAlAs and GaAs Diode sensors are supported from 25 to 475K. The maximum input voltage range of the monitor imposes this limitation.

Model 12/14 Supported Sensors		
	Temperature Range	Example Sensors
Silicon Diode	1.4 – 500K	Cryo-con® S700 Scientific Inst. SI-410 Lakeshore DT-670
GaAs Diode	25 – 475K	Scientific Inst. GA-300
Platinum RTD	14 – 1200K	Cryocon CP-100 Cryocon XP-100
Rhodium-Iron	1.4 – 800K	Oxford PHZ 0002
Germanium	0.5 – 100K	Lakeshore GR-200A
Carbon-Glass™	1.4 – 325K	Lakeshore CGR-1-500
Cernox™	0.3 – 325K	Lakeshore CX-1020
Ruthenium Oxide	0.05 – 200K	Scientific Inst. RO-600

Specifications

User Interface

Display Type: Graphics VFD, 10mm character height.
Number of Inputs Displayed: Two to four.
Keypad: Sealed Silicon Rubber.
Temperature Display: Six significant digits, autoranged.
Display Update Rate: 0.5 Seconds.
Display Units: K, C, F or native sensor units.
Display Resolution: User selectable to seven significant digits.

Input Channels

There are two input channels on the Model 12 and four on the Model 14, each may be independently configured for any of the supported sensor types.

Sensor Connection: 4-wire differential. DB-9 receptacle.
Sensor Types: See Supported Sensor Table.
Sensor Selection: Front Panel or remote interface.
Sensor Resolution: Sensor Dependent. See Sensor Performance Data table.
Sensor Excitation: Constant current: 1mA, 100 μ A or 10 μ A. Constant voltage: 10mV, 3.3mV and 1.0mV RMS with excitation currents from 1.0mA to 10nA in steps of 5% of power.
Resistance Measurement type: Ratiometric bridge.
Resistance Range: Constant-voltage resistance measurement range 10 Ω to 350K Ω .
AC Excitation Frequency: Resistor sensors in constant-voltage mode: 2.5Hz bipolar square wave.
Sample Rate: 10Hz per channel.
Measurement Resolution: Sensor Dependent. See Sensor Performance Data table.
Digital Resolution: 24 bits.
Digital Accuracy: 0.0015% of full scale.
Measurement Drift: <15ppm/ $^{\circ}$ C.
Measurement Filter: 0.5, 1, 2, 4, 8, 16, 32 and 64 Seconds.
Calibration Curves: Built-in curves for industry standard sensors plus four user curves with up to 200 entries each. Interpolation is performed using a Cubic Spline.

Data Logging

Data logging is performed to an internal, 20K-byte circular buffer and is time-stamped with a real-time clock. Buffer memory is non-volatile and will retain valid data without AC power.

Options and Accessories

Included Accessories

3038-029 User's Manual.
4034-029 Utility software CD.
04-0302 Relay Connector.
4034-038 Dual sensor input connector/cable assembly.
04-0310 Detachable 120VAC Line Cord.
Certificate of Calibration.

Optional Accessories

4012-040 Panel Mount hardware.
04-0420 RS-232 Null Modem cable.
4034-033 Shielded sensor connector kit.
S700 series Silicon Diode temperature sensor.
CP-100 series ceramic Platinum RTD temperature sensor.
GP-100 series glass Platinum RTD temperature sensor.

Analog Output

The analog output is a scaled voltage output that is proportional to any selected input temperature.

Output Range: Zero to 4 Volts.
Output Impedance: 500 Ohms.
Digital Resolution: 0.0015% of full-scale range.
Connection: Detachable terminal block.

Relay Outputs

Each relay output may be programmed to assert upon detection of a high or low temperature on any selected input channel.

Number: Two. Dry, Normally Open contacts.
Contact Rating: 30VDC at 1A. Connector:
Connection: 6-pin detachable terminal block.

Remote Interfaces

Ethernet: 10-BaseT. Electrically isolated.
TCP/IP user data socket provides remote control and interface to common data acquisition software by using an ASCII command language.
HTTP provides built-in web server.
SMTP sends e-mail based on user selected alarm conditions.

RS-232: Serial port is an RS-232 standard null modem. Data Rates are 9600, 38,400 and 57,600 Baud.

Language: Remote interface language is IEEE SCPI compliant on both the TCP/IP and RS-232 interface.

LabView[®] Drivers are available for the Ethernet TCP Data Socket and RS-232 interfaces.

General

Ambient Temperature: 25 $^{\circ}$ C \pm 5 $^{\circ}$ C for specified accuracy.
Mechanical: 8.5"W x 3.5"H x 12"D. One half-width 2U rack. Instrument bail standard, rack mount kit optional.
Weight: 5 Lbs.
AC Power Requirement: 110 or 220VAC, +5% to -10%, 50 to 60Hz, 30VA.
AC Power Switch: Rear panel.
Conformity: European CE certified.

Contact Information

Cryogenic Control Systems, Inc.

PO Box 7012
Rancho Santa Fe, CA 92067
Tel: (858) 756-3900 Fax: (858) 759-3515
E-mail: sales@cryocon.com Web: www.cryocon.com

CalGen[®] and Cryo-Con[®] are registered trademarks of Cryogenic Control Systems, Inc. All other product and company names are trademarks or trade names of their respective companies.

©Cryogenic Control Systems, Inc. 2005, M121105
Specifications subject to change without notice